

# Marine 6-Boat Free-Standing Racks

SKU: 30-0612

Updated November 2011

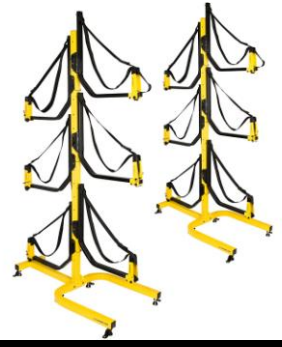

**Contains:**

- Marine 2-Boat Free-Standing Racks (SKU 12-0203)
- Marine 3<sup>rd</sup> Boat Expansion Racks (SKU 12-0303)
- 24" Marine Back Legs (SKU 22-0401)
- 3 Sets of Marine Deluxe Wall Mount Racks (SKU 12-0103)

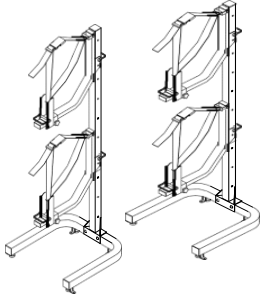

**Box #1**

Marine 2-Boat Free-Standing Racks	Qty
Use Instruction Sheet in Box	1

**Box #2**

Marine 3 <sup>rd</sup> Boat Expansion Racks	Qty
Use Instruction Sheet in Box	1

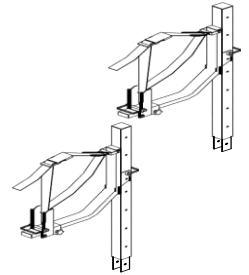

**Box #3**

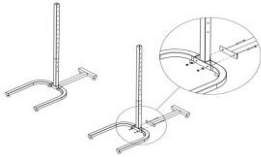

Marine 24" Back Legs	Qty
Use Instruction Sheet in Box	2

**Box #4, #5, #6**

Marine Deluxe Arms for Back Side of Rack	Qty
Use Instruction Sheet in Box	6

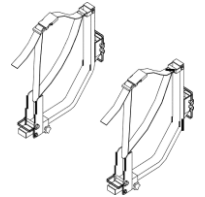

**Assembly Box #1:**

Use Marine 2-Boat Free-Standing Kayak Storage Racks (SKU 12-0203) Owner's Manual to assemble.

**Assembly Box #2:**

Use Marine 3<sup>rd</sup> Boat Expansion Racks (SKU 12-0303) Owner's Manual to assemble.

**Assembly Box #3:**

Use Marine Back Legs (sku 22-0401) instruction sheet in box to assemble.

**Assembly Box #4, #5, & #6:**

Place Marine Deluxe Racks (sku 12-0103) on back side of rack. Use instruction sheet in box to help with arm placement.

**Guarantee**

All Suspenz products are guaranteed for one year for materials and workmanship. The guarantee is affective to the original owner and if the product was cared for and used in the manner it was intended. Contact Suspenz directly with any questions.





**suspendz.com**

Patent No. 7,201,282

## Kayak, Canoe & SUP Storage Racks

Standard Grade: SKU 11-0103, 11-0203 and 11-0303

Marine Grade: SKU 12-0103, 12-0203 and 12-0303

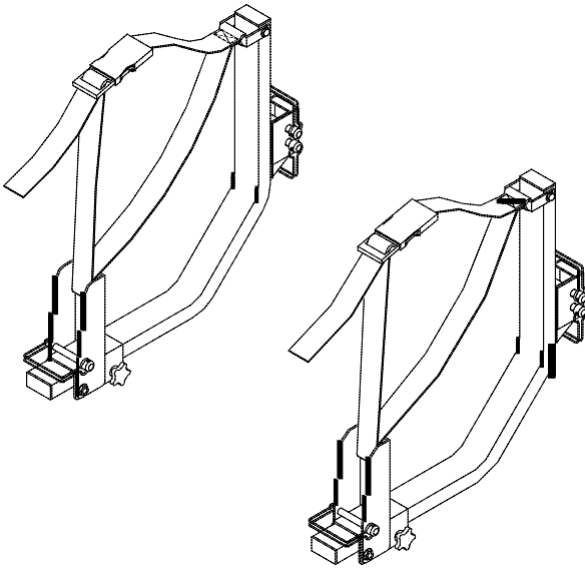

**Deluxe Wall Mount**

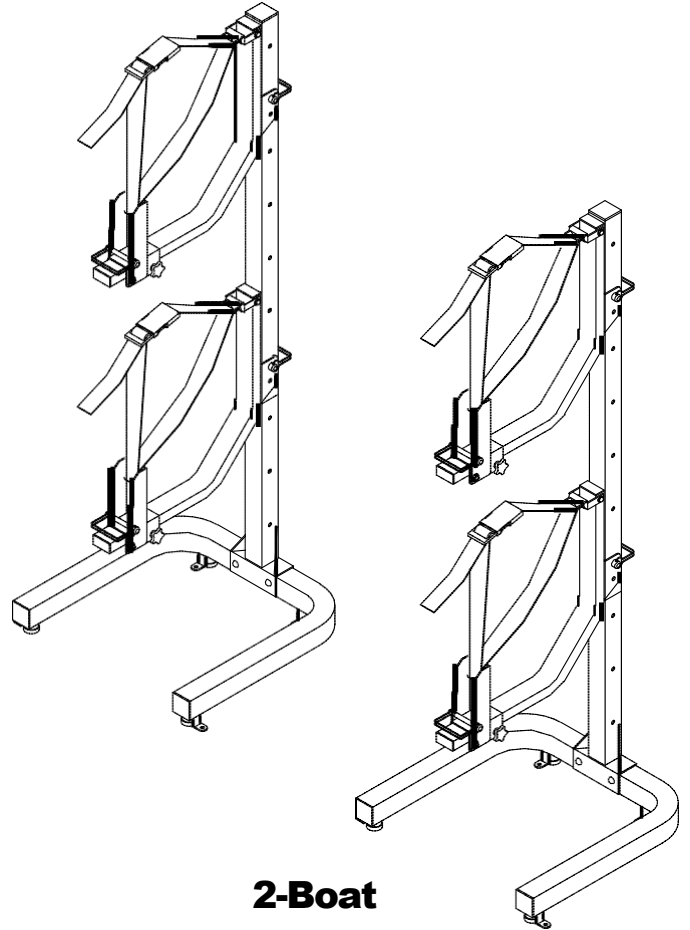

**2-Boat  
Free-Standing**

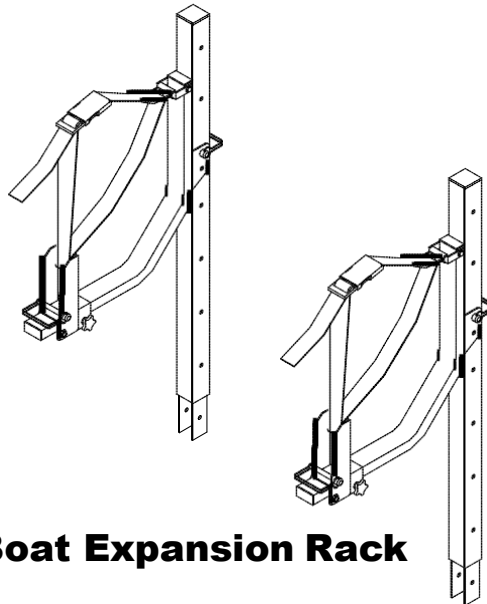

**3<sup>rd</sup> Boat Expansion Rack**

# Owner's Manual

Updated: October 2011

Suspendz™ Inc.  
8725 Roswell Road #0-220  
Atlanta, GA 30350  
770-518-0045  
web site: [Suspendz.com](http://Suspendz.com)

# TABLE OF CONTENTS

Important Safety Instructions	Page 2
Warranty Information	Page 3
Before Assembly	Page 3
Free Standing Rack Assembly	Page 4
Wall Mount Assembly	Page 6
Expansion Rack Assembly	Page 7
Rack Adjustment Instructions	Page 8
Use Instructions	Page 12
Safety Review	Page 13
Strap Threading	Page 13
Free-Standing Add-Ons	Page 14

## **SPECIAL NOTE:**

*Be sure to follow the "Rack Adjustment" section (pages 8-12) as this is where, when done correctly, you will understand and get the MOST out of these racks!*

# IMPORTANT SAFETY INSTRUCTIONS

## **Read all instructions before using this kayak storage rack.**

1. Before using read all the; Assembly Instructions, Adjustment Instructions, Use Instructions, Caution Notes and Safety Notes.
2. Do not modify this kayak storage rack.
3. Refer to the manual whenever you have a question.
4. If the user needs more assistance, please contact Suspenz before attempting to use this rack.
5. Do not allow children to play on the rack – with or without boats on it.
6. Inspect the rack on a monthly basis; make sure all the connections are tightly secured.
7. If the parts in the box do not match this Owner's Manual, do not assemble and contact Suspenz immediately for assistance. For more information go to [SUSPENZ.com](http://SUSPENZ.com).
8. If the rack is not working properly contact Suspenz immediately.
9. If the user does not follow these warnings and instructions, it could result in serious injury, material damage (boat or anything nearby) or even death.
10. The intended use for these racks is to store kayaks.
11. Racks hold 1 to 3 kayaks that are up to 34" wide (beam), 23" deep and 100 lbs per kayak.
12. Store only one kayak per suspension bar.
13. If adding a 4<sup>th</sup> boat to the floor base rack, mount anchoring hardware to a wall stud at the top of the tower (post).
14. Safety straps are an integral part of the suspension straps – they need to be fastened when the kayak is in storage.
15. Insert the locking pin into pivot arm when kayak is in storage, this is critical on all kayaks greater than 30 inches wide.

Suspenz can be reached by calling: 770-518-0045 Monday-Friday, 9:00 am to 6:00 pm (EST)

# WARRANTY INFORMATION

## **Limited Warranty**

**Suspenz, Inc** warrants your product against defects in materials and workmanship when used for the intended purpose of holding kayaks under normal use and conditions. Any unauthorized alterations or damage resulting from improper assembly will void this warranty.

This warranty is valid for one year on parts for the original owner only. The warranty begins from the date of purchase.

**Suspenz, Inc.** will provide a replacement part at no charge for any part found defective in material or workmanship during the warranty period. Under no circumstances will the manufacturer be responsible for damages or failures that occur as a result of improper assembly or failure to adjust and operate the storage racks correctly (per manual).

## **Return Policy**

30 day return policy with a 20% restocking fee. The original shipping and handling charges are non-refundable. User is responsible for Return Shipping costs. Or if bought from a retail store follow their policy.

Please contact Suspenz for a Return Authorization (RA) number before returning items, we will provide you with the shipping address at that time. 866-SUSPENZ (787-7369) or [returns@suspenz.com](mailto:returns@suspenz.com)

# BEFORE ASSEMBLY

Take a few moments to familiarize yourself with the specific parts hardware included with your product. Make sure all the parts and hardware are included in the cartons and examine them for any damage that may have occurred in transport. Some parts may be pre-assembled.

## Tools Required for Assembly:



**Tape measure**



**1/2" Wrench**  
(supplied with Free-Stand Rack)



**3/16" drill**  
(for wall mount only)

**Plus: A cold beverage of your choice**

# FREE STANDING RACK

## Assembly Step 1

Follow the assembly procedure in order of A-B-C

Check carton for following parts that are needed to complete Step 1 of your Free Standing Rack

Part Name	Qty
Leveling Foot	8
Anchor	8
3/8" Hex Jam Nut	8
Base	2
Base Post	2
5/16" x 2 3/4" Carriage Bolt	4
5/16" Washer	8
5/16" Locknut	4
Post	2
5/16" Lock Washer	4
5/16" x 1" Hex Bolt	4
1/2" Hex Wrench	1
Extension Strap (not shown)	4

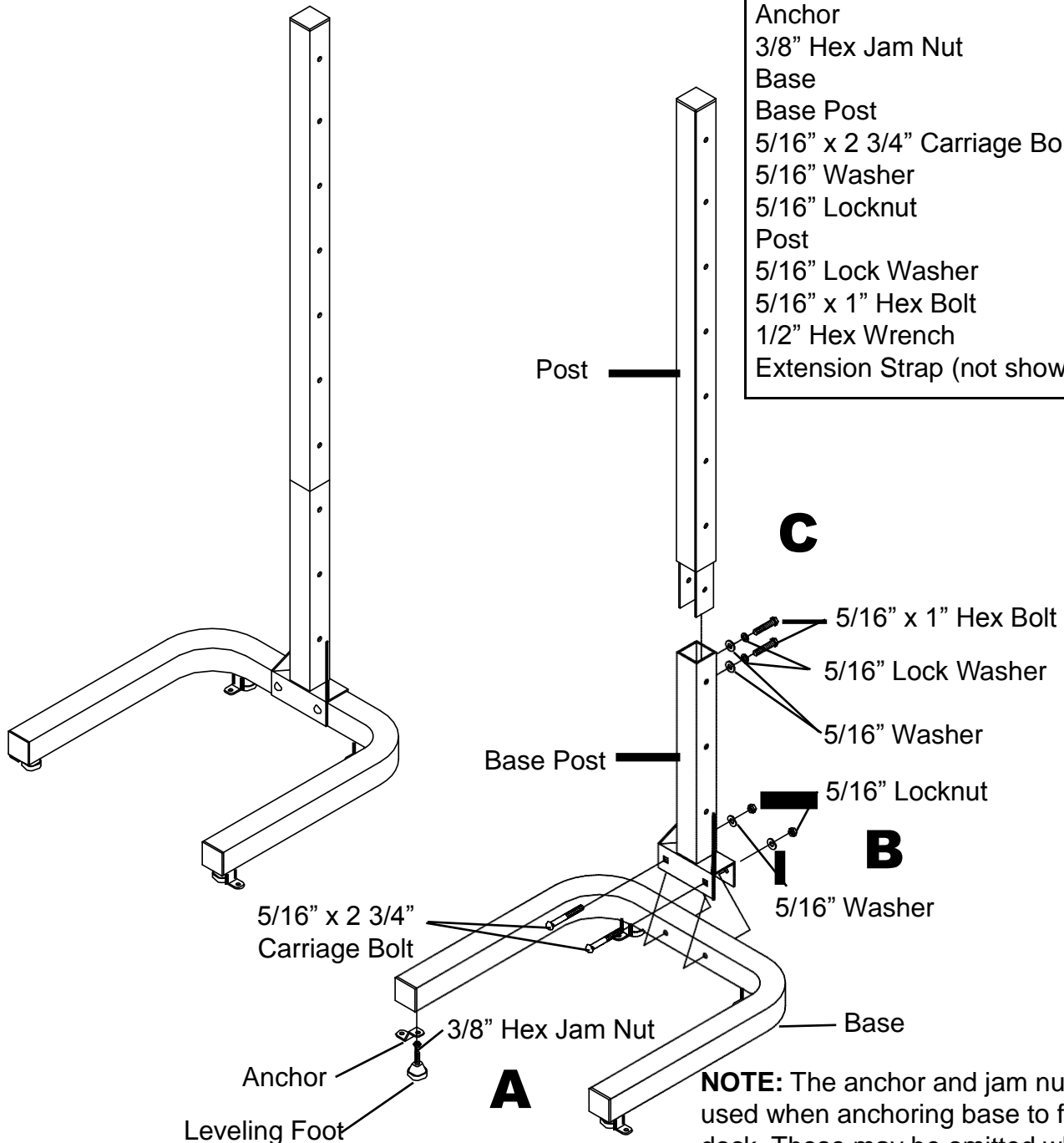

**NOTE:** The anchor and jam nuts are used when anchoring base to floor or dock. These may be omitted when base is on a stable level surface/environment.

# FREE STANDING RACK

## Assembly Step 2

Follow the assembly procedure in order of A-B

Check carton for following parts that are needed to complete Step 2 of your Free Standing Rack

Part Name	Qty
Suspension Bar	4
Locking Pin	8

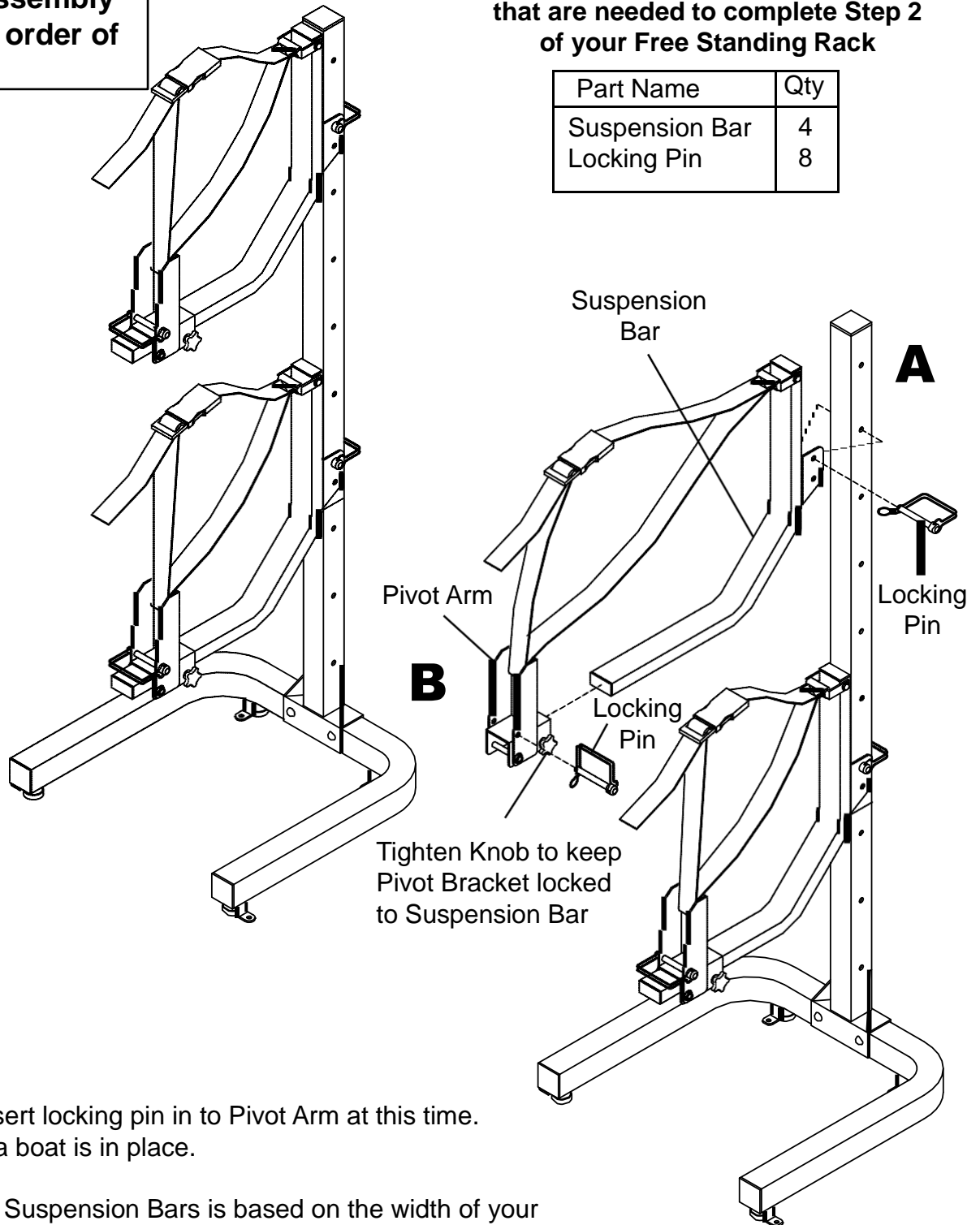

**NOTES:** Do not insert locking pin in to Pivot Arm at this time. It is inserted once a boat is in place.

The location of the Suspension Bars is based on the width of your boats. See picture in Adjustment Instructions, adjustment 3.

# WALL MOUNT RACK

## Assembly

Follow the assembly procedure in order of A-B-C

Check carton for following parts that are needed to complete assembly of your Wall Mount Rack

Part Name	Qty
Wall Mount Bracket	2
1/4" x 2" Phillips Head Screw	4
1/4" Flat Washer	4
Suspension Bar	2
Locking Pin	6
Extension Strap (not shown)	2

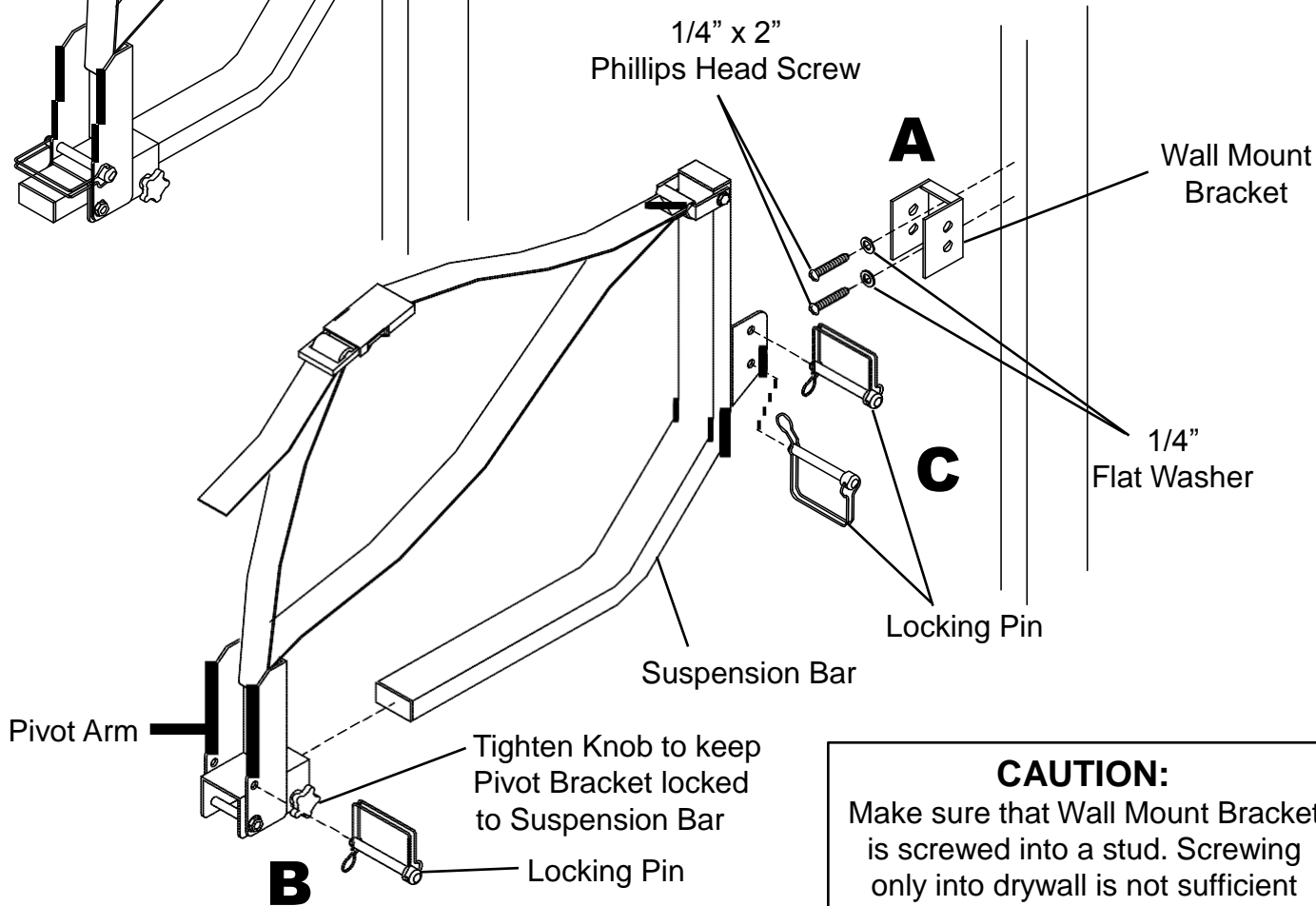
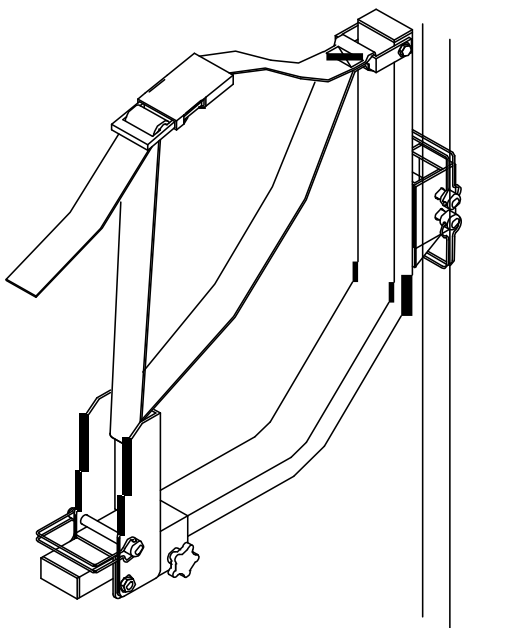

**CAUTION:**  
Make sure that Wall Mount Bracket is screwed into a stud. Screwing only into drywall is not sufficient

**NOTES:** The horizontal distance between the wall mounts should be 40% to 50% of the length of the boat. (SEE CHART on page 8). Do not insert locking pin into Pivot Arm at this time. It is inserted once a boat is in place.

# EXPANSION RACK Assembly

Follow the assembly procedure in order of A-B-C

Check carton for following parts that are needed to complete assembly of your Expansion Rack

Part Name	Qty
Post	2
5/16" Washer	4
5/16" Lock Washer	4
5/16" x 1" Hex Bolt	4
Suspension Bar	2
Locking Pin	4
1/2" Hex Wrench	1
Extension Strap (not shown)	2

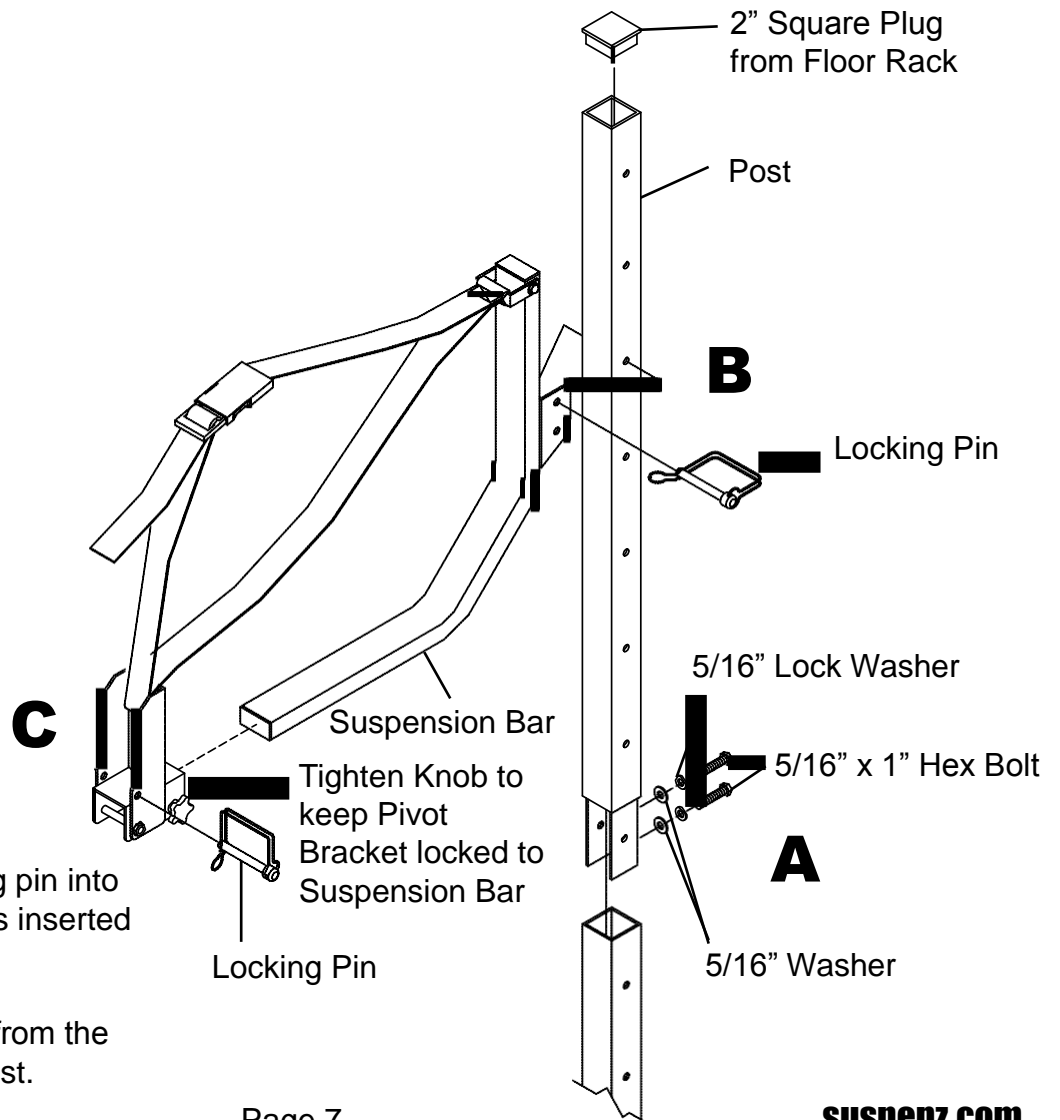
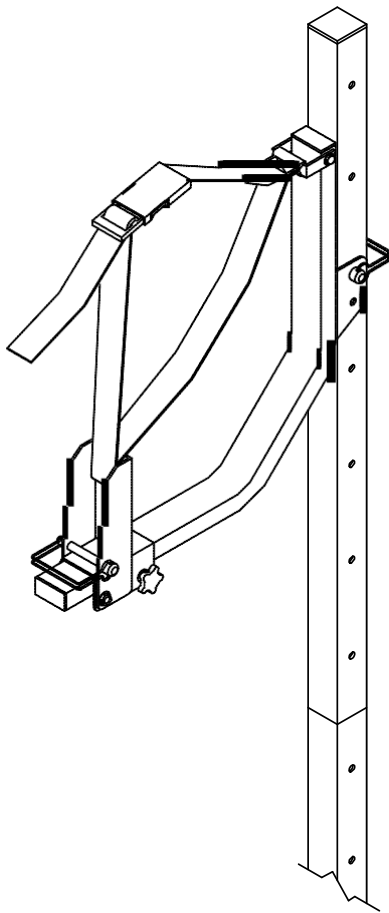

**NOTES:** Do not insert locking pin into the Pivot Arm at this time. It is inserted once a boat is in place.

Remove the 2" Square Plug from the Floor Rack and insert into Post.



# RACK ADJUSTMENT

## Instructions for All Boats

3 sets of adjustments are needed based on the length, width and depth of your boats:

3 Simple Adjustments to fit your kayak:

- A. LENGTH: The length of your longest boat will determine the “tower” (or wall mount) spacing.
- B. WIDTH: The width of each boat defines where the “suspension bar” is placed on the post.
- C. DEPTH: The depth of each boat defines the position of the pivot arm and the length of the straps that your boat is suspended on.

1.) Boat **Width**: vertical position of the suspension bar

2.) Boat **Depth**: pivot arm & strap adjustment



3.) Boat **Length**: distance between center of towers

For WALL MOUNT RACKS skip adjustment 2.

Tower/Wall Mount Brackets  
Suspensz SPACING GUIDELINES®

Boat Length	Ideal Tower (or wall mount bracket) Spacing (40%)	The min/max spacing for each kayak (35% / 50%)
8'	3' 2"	2' 10" min. / 4' max
8' 6"	3' 5"	3' min. / 4' 3" max
9'	3' 7"	3' 2" min. / 4' 6" max
9' 6"	3' 10"	3' 4" min. / 4' 9" max
10'	4'	3' 6" min. / 5' max
10' 6"	4' 2"	3' 8" min. / 5' 3" max
11'	4' 5"	3' 10" min. / 5' 6" max
11' 6"	4' 7"	4' min. / 5' 9" max
12'	4' 10"	4' 2" min. / 6' max
12' 6"	5'	4' 5" min. / 6' 3" max
13'	5' 2"	4' 7" min. / 6' 6" max
13' 6"	5' 5"	4' 9" min. / 6' 9" max
14'	5' 7"	4' 11" min. / 7' max
14' 6"	5' 10"	5' 1" min. / 7' 3" max
15'	6'	5' 3" min. / 7' 6" max
15' 6"	6' 2"	5' 5" min. / 7' 9" max
16'	6' 5"	5' 7" min. / 8' max
16' 6"	6' 7"	5' 9" min. / 8' 3" max
17'	6' 10"	5' 11" min. / 8' 6"
17' 6"	7'	6' 2" min. / 8' 9" max
18'	7' 2"	6' 4" min. / 9' max
18' 6"	7' 5"	6' 6" min. / 9' 3" max
19'	7' 7"	6' 8" min. / 9' 6" max
19' 6"	7' 10"	6' 10" min. / 9' 9" max
20'	8'	7' min. / 10' max
20' 6"	8' 2"	7' 2" min. / 10' 3" max
21'	8' 5"	7' 4" min. / 10' 6" max
21' 6"	8' 7"	7' 6" min. / 10' 9" max
22'	8' 10"	7' 8" min. / 11' max
22' 6"	9'	7' 11" min. / 11' 3" max

### A.) Adjustments based on boat LENGTH:

#### Adjustment 1: Tower (or wall mount) Spacing:

Measure the length of your kayak. Position the towers (or wall mounts) so the length and weight of the boat are balanced equally on the suspension straps, meaning the distance between them is ~40% of the length of kayak.

*Example: If your kayak is 16' (192") long, the center of the towers should be 77" apart. (192" x .4 = 77" / 6'5")*

← Here is a spacing guide line® chart to help you decide what will work best for you.

#### Adjustment 2: Level the Towers

##### a) Eliminate Rocking:

Rotate the leveling feet by hand so that all four feet make contact with the floor. It is important that the base does not rock.

##### b) Side - Side Leveling:

If post is not vertical adjust both feet on one side of the base to make the post vertical (this is a good time to use the level).

##### c) Fore – Aft Leveling:

Rotate the two front feet by a similar amount so that the post is vertical or has a slight backward lean (*this is a good time to use the level*). The post should not lean forward in the unloaded state. It is normal for the posts to tilt slightly forward when boats are loaded.

## B.) Adjustments based on boat WIDTH:



### Adjustment 3: Set the height of the lowest Suspension Bar

The lowest height for the bottom Suspension Bar is shown. The Locking Pin (11) goes through the lower hole of the Suspension Bar (10) and the **center hole** of the base post (2).

We suggest starting at this lowest position if one of the boats is wide (> 30 inches). If all of your boats are narrow, you can start with a higher bottom position.

The next suspension bar position should leave a 2"-6" gap above the lower boat. (See Adjustment 8)

**NOTE:** Place the widest boat on the bottom rack position. (this maximizes rack stability)

## C.) Adjustments based on boat DEPTH:

### Adjustment 4: Set the position of the Pivot Arm

Boats can vary greatly in their cross section. The next two adjustments are starting point adjustments that work well for an average boat. You may need to fine tune them once your boat is in place. Once the Pivot Arms and straps are adjusted, they will not need to be adjusted again for the same boats.

You will need to determine the depth of your boat at its' suspension points. Lay your boat flat on the ground centered in front of the towers as if you were getting ready to place it in the rack.

Now measure the depth of the boat at the points that line up with each tower. Write down these depths.

Adjust the Pivot Arm distance on each Suspension Bar so that it equals the depth of the boat + 4 1/2 inches. Tighten knob to lock pivot bracket in place.

**NOTE:** If knob doesn't tighten completely then unscrew knob and add a washer.

**Caution:** Do not exceed 18½" inches for the Pivot Arm Distance so that locking pin will engage.



### Adjustment 5: Set the Strap Length

Adjust the length of the support strap so that the Pivot Arm lays horizontal when the strap is tight, as show.

**NOTE:** Pivot arm should fall freely, If not, loosen hex bolt and nut (item 8 & 21) with hex wrench.

## Adjustment 6: Verify Adjustments and Fine Tune

Since boats can vary greatly in their cross section, you may need to fine tune adjustments 4 & 5. Set Pivot Arms in their horizontal (open) position. Place the boat in the rack to assess the fit.

*If you have not yet opened your cold beverage, this would be an appropriate time to do so.*

a) Pivot arms are adjusted to “suspend” boat on its side so it is nearly at right-angle to the floor (be sure to tighten knob when adjusting Pivot arms).

Top of boat should lean slightly toward back of rack when on its side (this prevents the boat from falling forward).

There should be a small gap between the top of the pivot arm and the boat such that the pivot arm does not touch the boat.

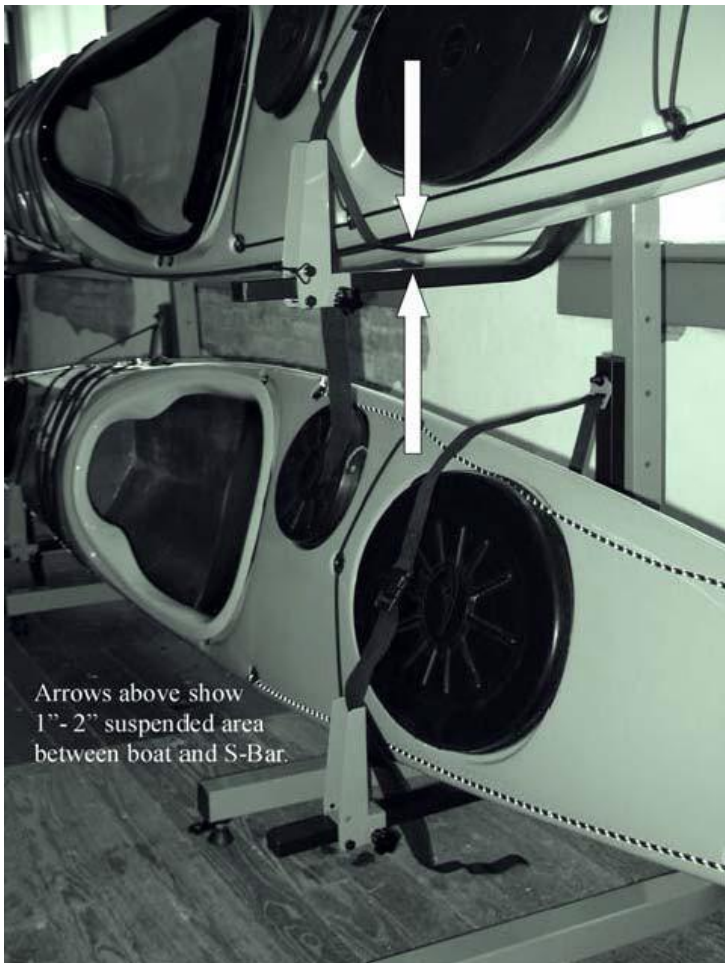

b) There should be a gap of about 1-2 inches between the boat and the suspension bar. Adjust the length of the strap to achieve this.

**Caution:** The boat should be removed before adjusting the strap length (strap length is adjusted at the pivot arm).

## Adjustment 7: Adjust Safety Strap and Add Extension Strap if Needed

Verify that the safety strap can be connected over the top of the boat. For some larger boats, you will need to add the Extension Strap to have enough length.



Adjust the safety strap length to achieve a snug fit.

## Adjustment 8: Configure For the Next Boat

Add the Suspension Bars for the next boat then repeat adjustments 4 – 7 for this boat. Repeat again if you are using the Expansion Rack to hold 3 boats.

### Next Suspension Bar Position:

Position the next set of Suspension Bars to leave a small gap (2 - 6 inches) above the boat below.

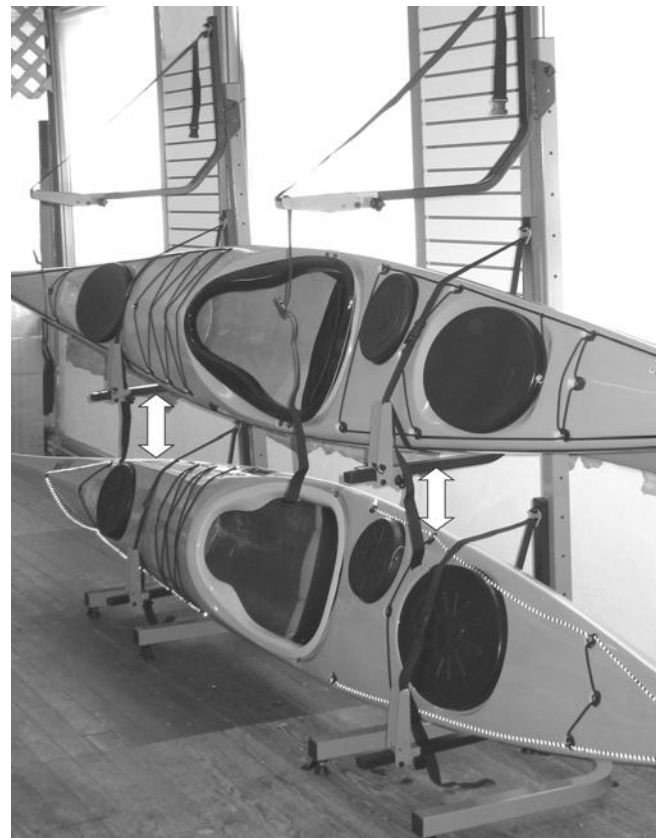

# USE INSTRUCTIONS

## To load

Open pivot arms (horizontal) toward front of rack, this will give more clearance for boat and ease loading.

Center boat so same amount of the boat is “suspended” beyond each end of straps.

When boat is positioned on its side and lowered onto straps, the Pivot arms will snap up into vertical position... *The Magic Moment!*

Adjust angle of boat to a secure resting position, fasten safety straps.



**NOTE:** top side of boat should lean slightly toward back of rack when boat is on its side. This prevents the boat from falling forward.

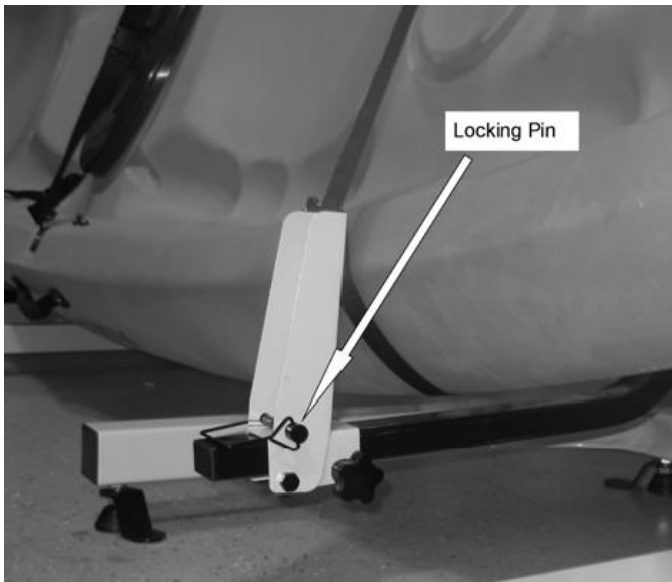

Insert locking pin into pivot arm to lock it in the closed position.

**Important: This is a safety requirement to prevent pivot arms from opening unintentionally.**

## To unload

Remove locking Pin (place locking pin in an empty post hole for safe storage) Release safety straps, lift boat slightly and move toward front of rack. You do not need to lift your boat over the pivot arms, they will fall forward automatically when weight of boat has been lifted.

## SAFETY REVIEW

- Allow enough time to set up racks properly. Make sure hardware is securely tightened. Install racks on a level surface.
- Once racks are set up, check for stability, secure (adjustment 2) or re-locate racks if necessary.
- Anchors on leveling feet should be secured with a screw (not supplied) to floor if additional stability is needed. **This is a requirement if on a dock.**
- Be sure to fasten safety straps and insert locking pins in pivot arms when storing boats.



## STRAP THREADING

The strap will be threaded through the pivot arm when received however, if you need to rethread it follow these instructions::

### Step 1



### Step 2



### Step 3



### Step 4



### Step 5



### Step 6



## Customize your Free-Standing Racks

Add Any of These Parts...



Cross Bar



Back Legs

Expansion Posts

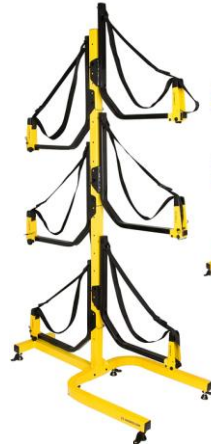

6-Boat Racks



Casters



EZ Racks



SUP Racks (1 or 2)



Canoe Flat Racks

## See our selection of Portable Boat Stands and Kayak & Canoe Carts



24" & 33" Portable Boat Stands



Smart DLX Cart



Smart SK Cart



Smart Sit-On-Top Cart

[www.suspenz.com](http://www.suspenz.com)



**Suspenz Inc.**  
 8725 Roswell Road #0-220  
 Atlanta GA 30350  
 770-518-0045

**KAYAK-CANOE storage racks**  
**Suspenz™**

# Marine Grade 24" Back Legs

To be used with Marine Grade Free-Standing Racks

SKU 22-0401

Updated October 2011

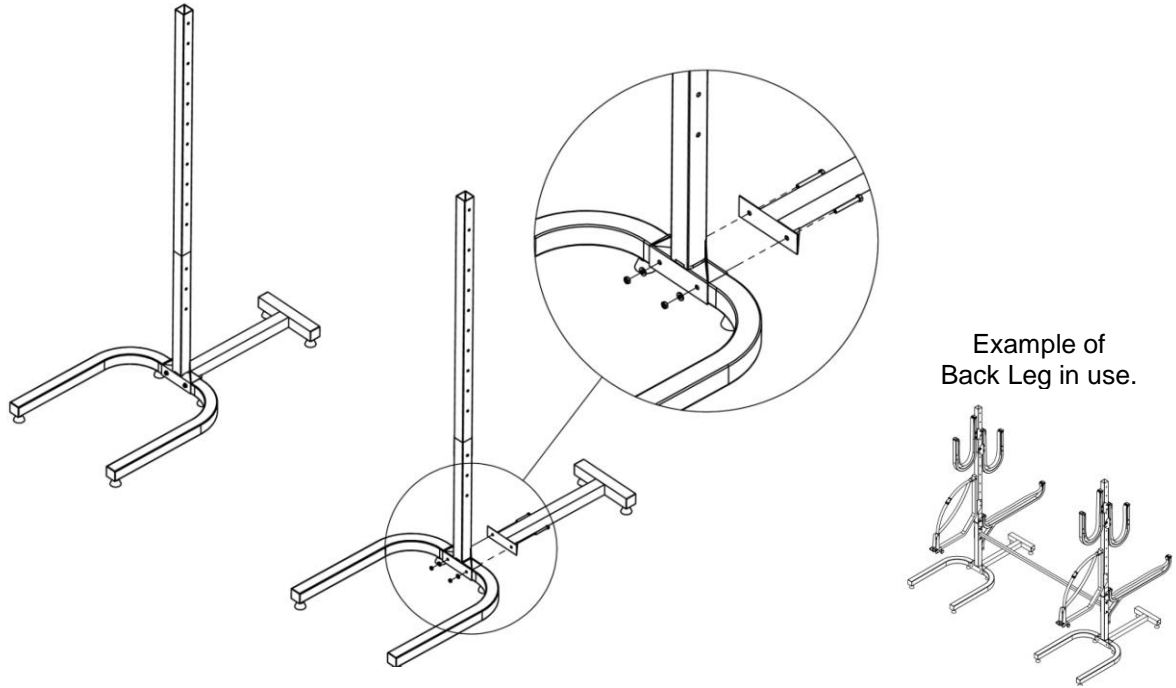

**Tools Required:**

1. Adjustable Wrench

Item #	Parts List	Qty
1	Black Back Leg	2
2	Leveling Foot	4
3	Anchor	4
4	Hex Jam Nut	8

**Assembly:**

1. Remove the carriage bolts, washers & lock nuts from original Free-Standing Floor Base & Base Post.
2. Line up Back Leg to Free-Standing Floor Base; attach Back Leg **using the original hardware.**

**NOTE:** When putting attachments on the back-side of the rack, they should not extend more than 24". Currently the SUP Racks, EZ Racks and Marine Grade Deluxe Racks will work well on the backside. Cross-Bar is required when casters are used.

**Guarantee**

All Suspenz products are guaranteed for one year for materials and workmanship. The guarantee is affective to the original owner and if the product was cared for and used in the manner it was intended. Contact Suspenz directly with any questions.

