

DD-B-1635

QUOTE NO. \_\_\_\_\_

DATE: \_\_\_\_\_

MODEL NO.: \_\_\_\_\_

**NOTES:**

1. DO NOT SCALE PRINT, TYPICAL DIMENSIONS ONLY.
2. SPECIFICATIONS AND DIMENSIONS ARE SUBJECT TO CHANGE WITHOUT NOTICE OR OBLIGATION.
3. ALL DIMENSIONS IN INCHES.
- ④ ADD 1.00" TO HEIGHT FOR VIBRATION ISOLATION OPTION.
- ⑤ OPTIONAL EQUIPMENT MAY EFFECT DIMENSION.

**PUMP CONFIGURATION:**

- STD
- HEAD UNLOADERS/DUAL CONTROL

MOTOR: \_\_\_\_\_ HP/VOLTS/PH/HZ

- ODP(STD)
- TEFC ⑤
- HIEFF ⑤

RECEIVER SIZE(Gal.)

- 250
- VINYL
- GALVANIZED

**OPTIONAL EQUIPMENT**

- STARTERS/ ALTERNATOR
- DUPLEX CONTROL PANEL ⑤
- FUSED DISCONNECT ⑤
- LOSC
- AIR-COOLED AFTERCOOLERS
- AUTO TANK DRAIN
- TIMED TANK DRAIN
- VIBRATION ISOLATORS ④
- OTHER

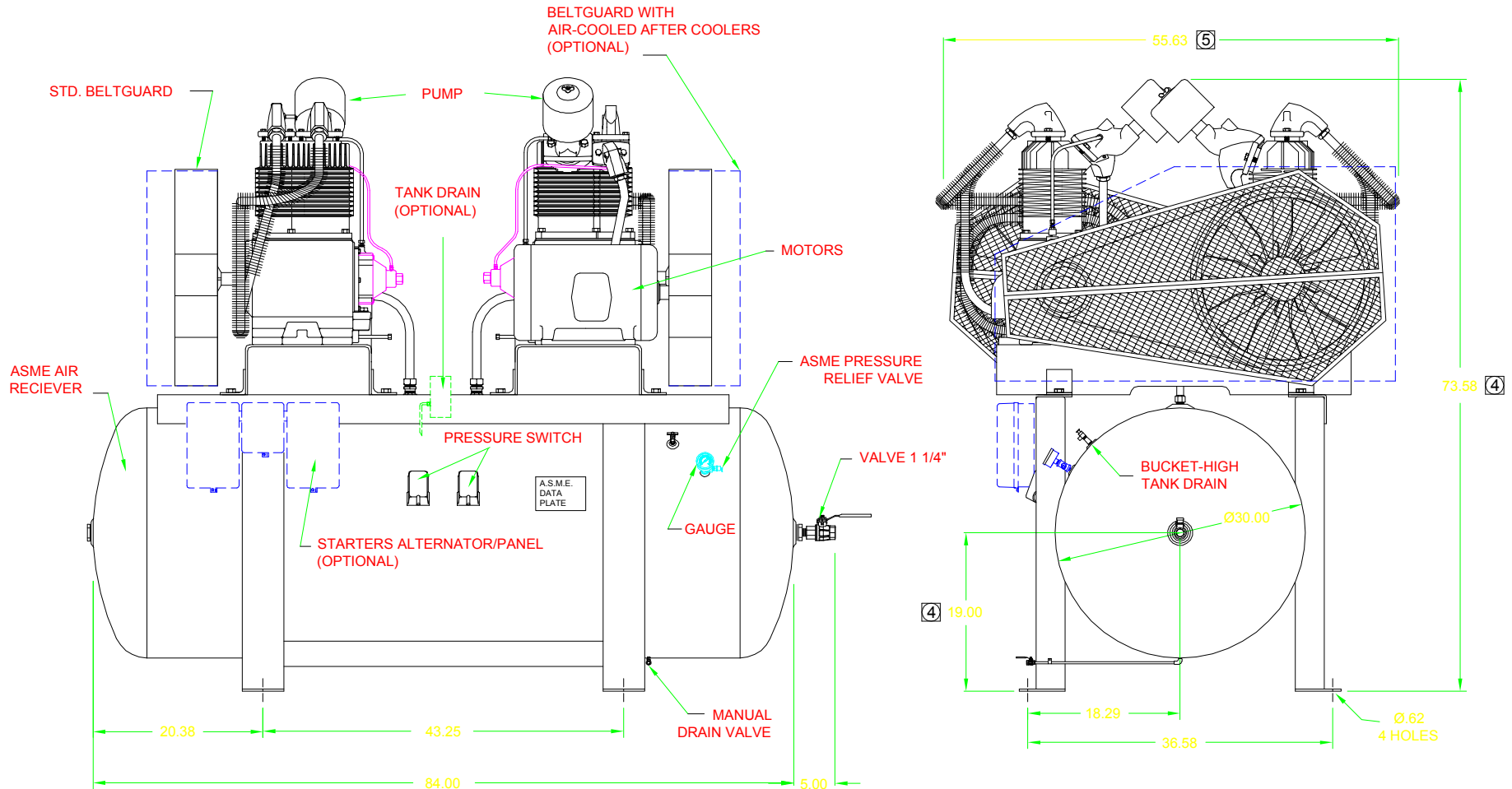

**NOTICE:**

REFERENCE DRAWING ONLY MAY NOT INCLUDE SPECIFIC ACCESSORY ITEMS FOR ANY PARTICULAR ORDER.

**CHAMPION- A GARDNER DENVER COMPANY**

**GENERAL ARRANGEMENT**

R40  
DUPLEX TANKMOUNT

PRINT NO.: DD-B-1635

REV. DATE:

DRAWN BY: G.L.

DATE: 05/05/2000

CHK'D BY:

DATE: